



ASSEMBLY INSTRUCTION

TRAVIS FABRIC 2 SEATER RECLINERS

ITEM CODE 81164

Imported by Amart Furniture Pty Ltd, Qld, Brisbane Australia.

For any assistance with assembly or for missing parts please phone

Amart Furniture , Customer Service Free call 1800 351 084

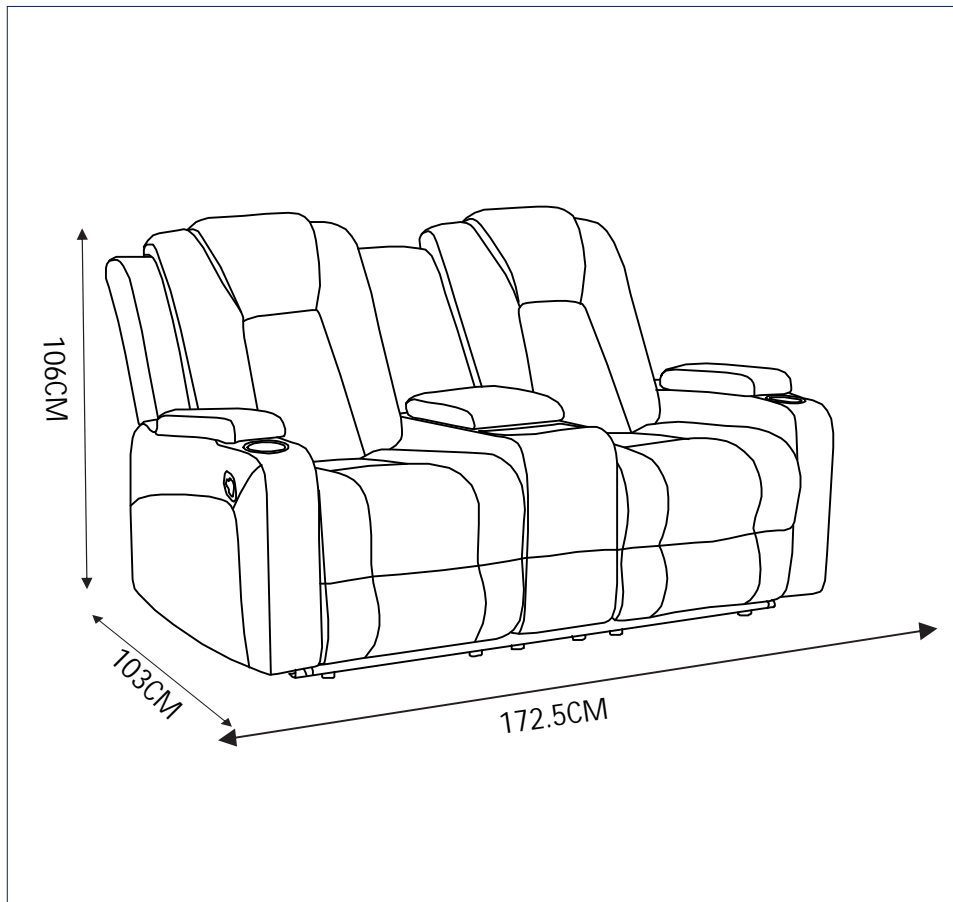

Imported by Amart Furniture Pty Ltd, Brisbane QLD Australia.

For any assistance with assembly or for missing parts please phone

Amart Furniture, Customer Service Free call 1800 351 084

PRE-ASSEMBLY PREPARATION

Before you start:

1. Choose a clean, level, spacious assembly area. Avoid hard surfaces that may damage the product
2. Take care when lifting. Product should be assembled as near as possible to the point of use
3. Ensure that you have all required contents for complete assembly
4. Always read the assembly instructions carefully before beginning assembly
5. Keep all hardware parts and packaging out of reach of small children
6. Do not over tighten the screws and bolts as this may damage the threads
7. Do not use a knife when opening

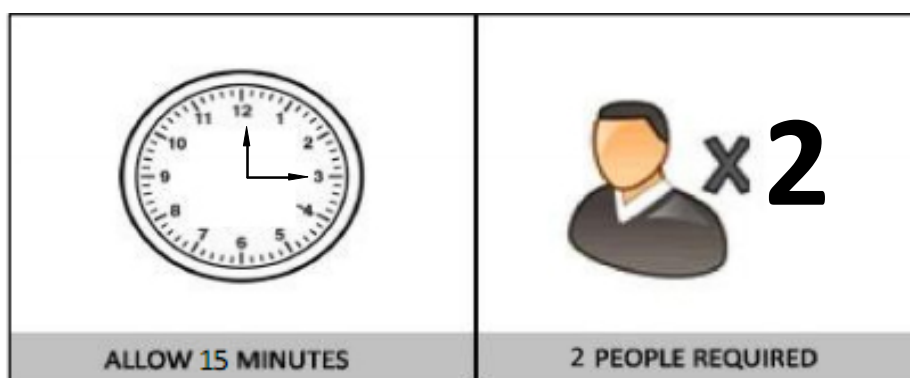

WARNING

Do Not allow children to play on this mechanised furniture or operate the mechanism. Leg rest folds down on closing so that a child could possibly be injured. Always leave in an upright and closed position. Keep hands and feet clear of mechanism. Only the occupant should operate it.

PARTS LIST

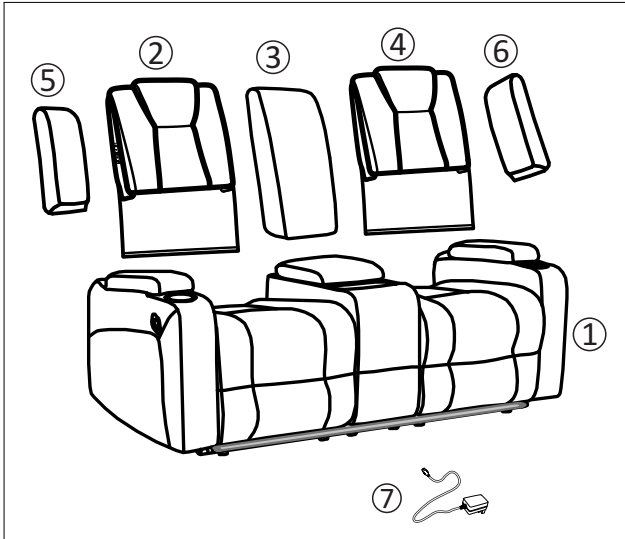

1	SEAT
2	LEFT BACKREST
3	MIDDLE BACKREST
4	RIGHT BACKREST
5	LEFT ARM
6	RIGHT ARM
7	POWER PLUG

STEP 1: Install back ③ on seat ①.

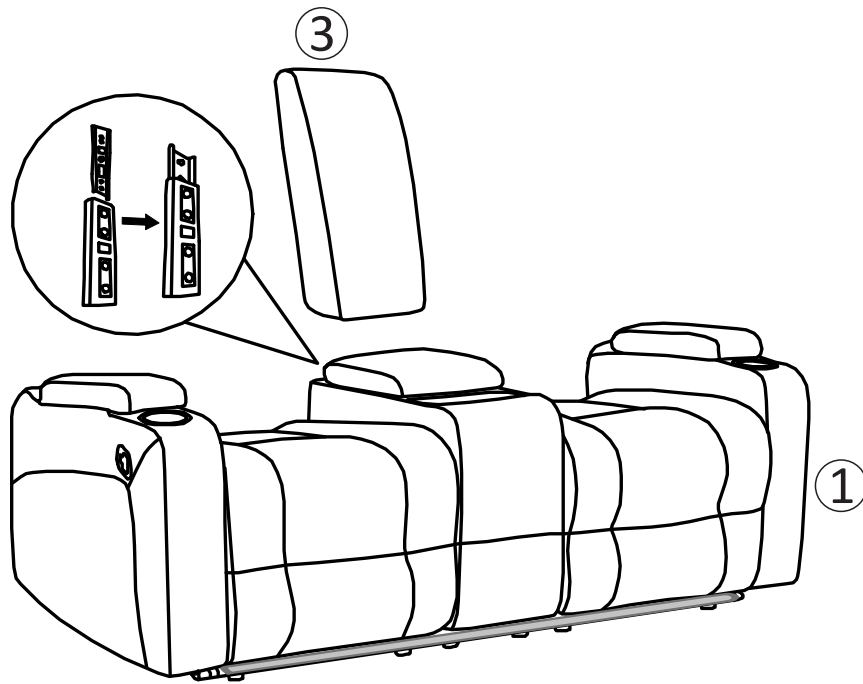

STEP 2: Install back ② ④ on seat ①.

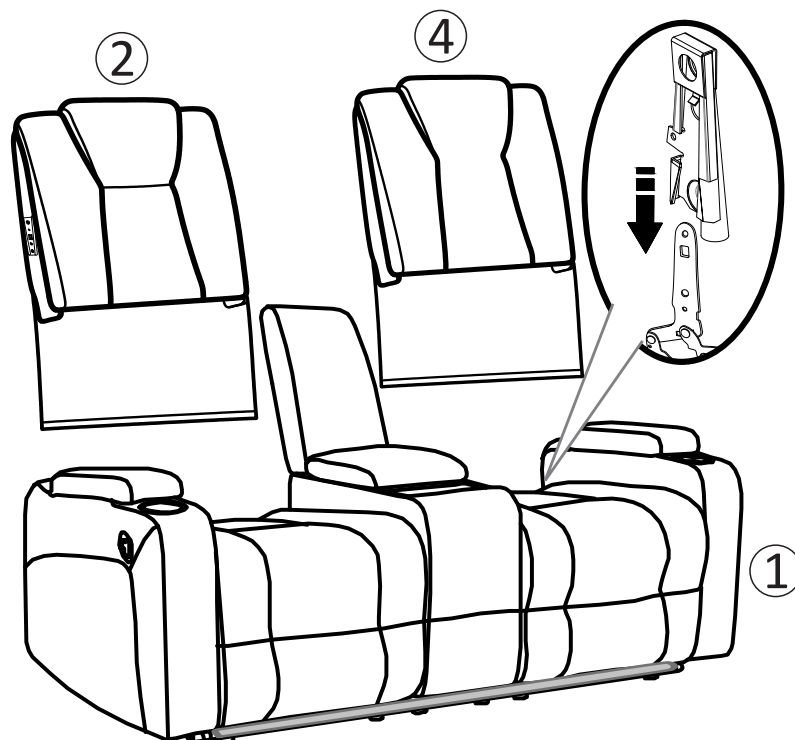

STEP 3: Install armrest ⑤ and ⑥.

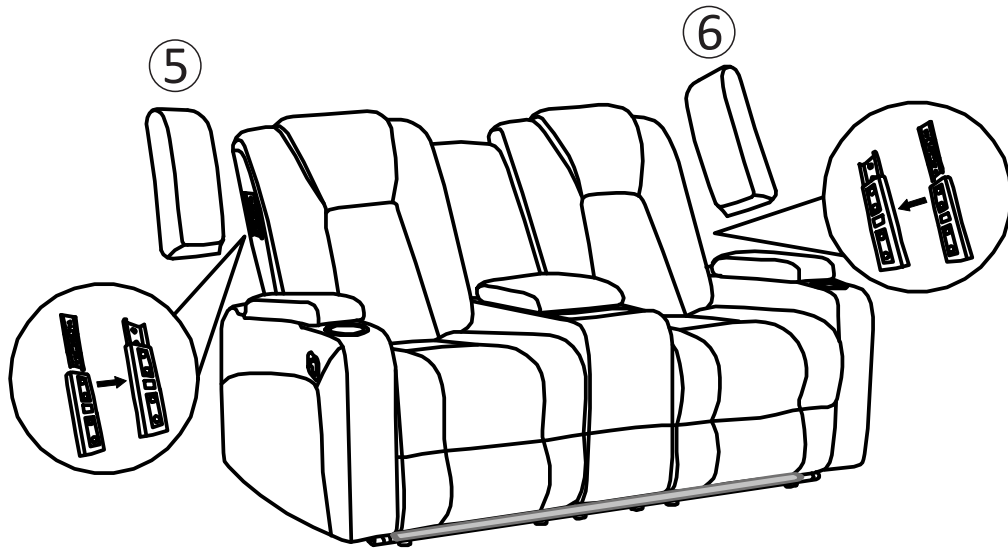

STEP 4: Assembly complete. To operate the recliner, use the handle on the side of the base.

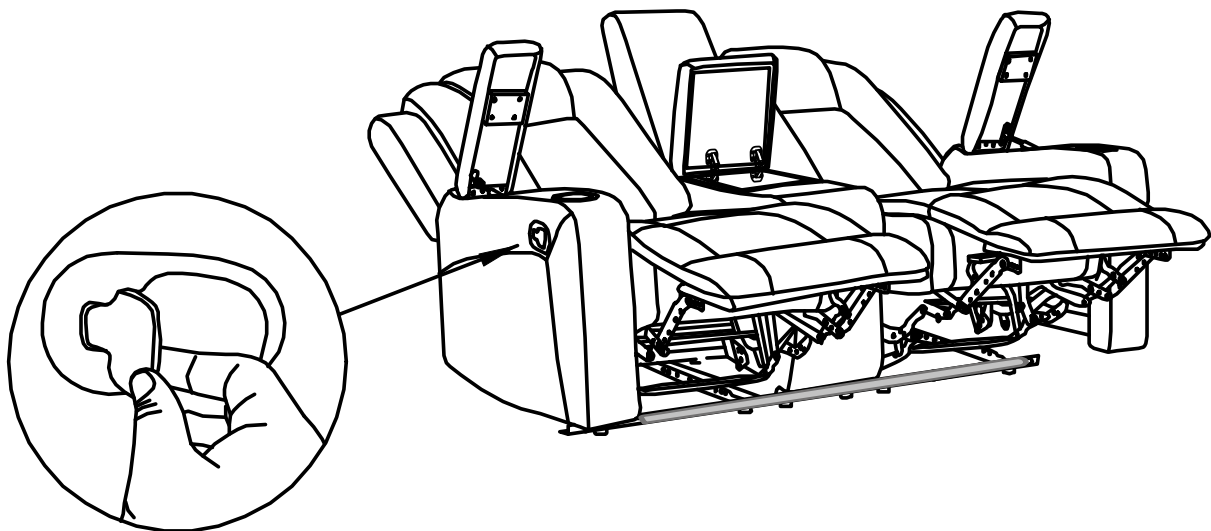

STEP 5: As shown in the figure, this button is the switch for the sofa light tube.

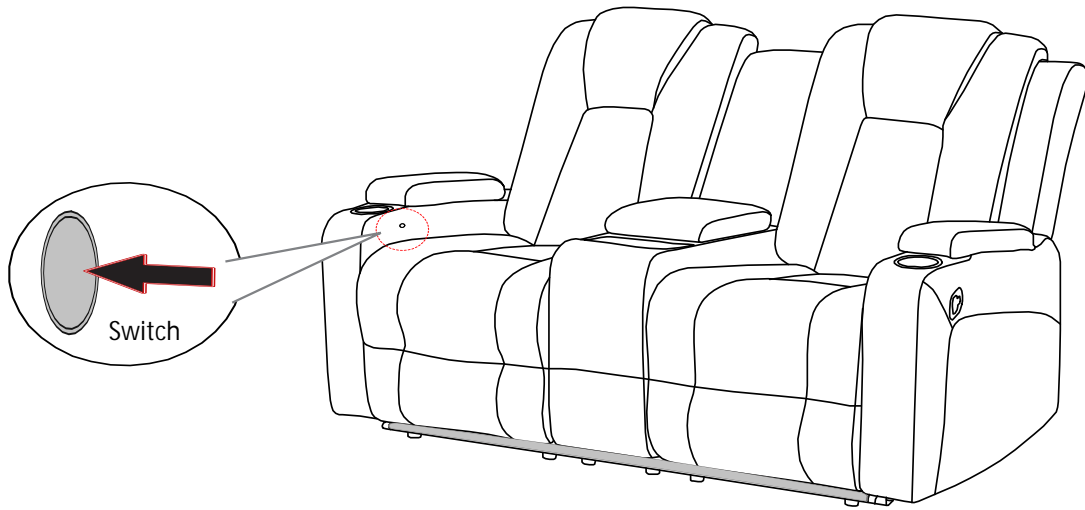

STEP 6: Connection of light strip.

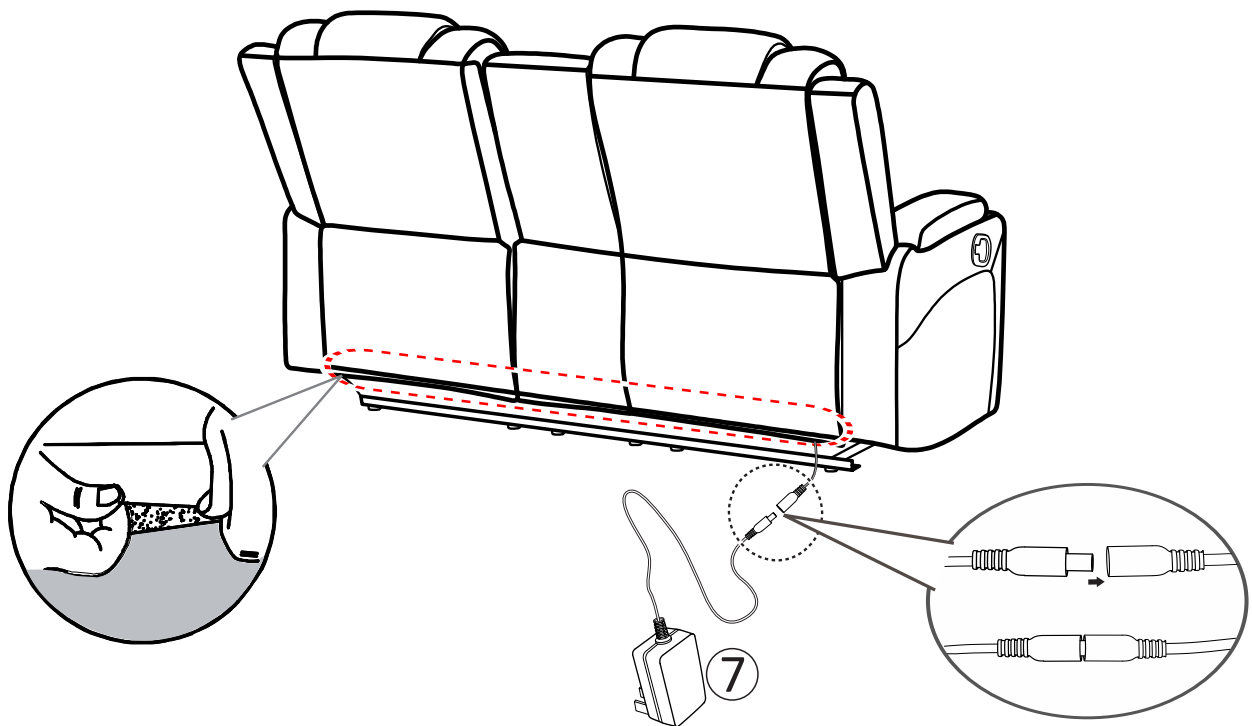

IMPORTANT NOTE:

PLEASE ENSURE THAT ALL ELECTRICAL CORDS AND CABLES ARE CLEAR OF THE FRAME AND MECHANISM. FAILURE TO DO SO MAY SEVER YOUR POWER CORD RESULTING IN SERIOUS INJURY OR DEATH.

SAFETY NOTE

WARNING! AVOID POTENTIAL EQUIPMENT DAMAGE OR ELECTRIC SHOCK! DO NOT PLACE THE TRANSFORMER UNDER OR WITHIN THE RECLINER STRUCTURE.

DO NOT COVER THE TRANSFORMER. KEEP IT IN AN OPEN, WELL-VENTILATED AREA FREE FROM FOREIGN MATERIAL / DEBRIS TO ENSURE PROPER OPERATION.

ASSEMBLY IS COMPLETE

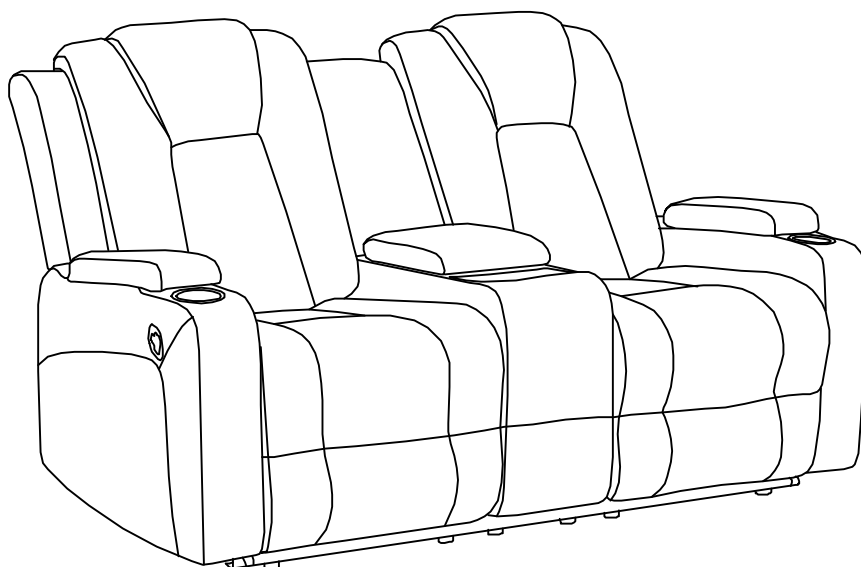

READ THESE INSTRUCTIONS THOROUGHLY BEFORE USE:

It is crucial to handle your reclining sofa with care. Following the intended usage guidelines will ensure safety and product longevity.

Recliners have a metal mechanism base, with moving parts to allow reclining functions. These components are flexible but can be easily bent or twisted if subjected to excessive weight, improper use, or excessive motion.

Safety

Moving parts; particularly reclining mechanisms can be dangerous if used incorrectly:

- ALWAYS supervise children when they are around or on reclining furniture. Prevent them from operating the mechanism or playing on the recliner.
- Only the occupant should operate the recliner. When not in use, ensure it is returned to the lounges closed position.
- When closing the recliner-
- Always check underneath the mechanism to ensure that the footrests are folded down properly.
- Avoid placing hands and feet near the mechanism.
- Be mindful of children and pets, and the possibility of trapping items like clothing or blankets in the mechanism.

It is recommended that the closing motion be closed slowly.

General Care

It is crucial to use recliners carefully and in accordance with their intended design to maintain their structural integrity. Misuse of the reclining mechanism can lead to bending or bowing. All Amart sofas have a weight capacity of 120kg per seat.

- Always ensure that footrests are fully closed before entering or exiting the seat. Using the seat with the footrest open can damage the structure and is not the intended usage.
- While reclined, the footrests are designed to support the weight of a single person's feet. Excessive weight, especially from pets and children, can overload the mechanism and cause twisting and bowing.
- Avoid leaning on the sides of the recliner at any time. Reclining seats are designed to be sat on in the middle as the centre of the cushion provides structural support. Leaning over the sides of the seat can twist the mechanism.
- Ensure that when you close the mechanism that equal weight is placed on the centre of the footrest panel. Do not close from the edges of the recliner's footrest. This causes stress on the mechanism and leads to a broken and bent mechanism. This is not a manufacturing fault but a result of improper use.

Positioning your recliner

It is imperative that you ensure your recliner is positioned on a level surface to ensure its longevity.

Positioning your recliner on an unlevel or sloping surface can put additional strain on the internal components of your recliner.

The internal components of the recliner, such as the frame, levers, and hinges may experience increased stress if the recliner is constantly used on an uneven surface. Over time, this leads to premature wear and tear, affecting the recliner's durability, stability, and performance.

Additional issues that can impact electric recliners if positioned on an unlevel floor are as follows:

- 1.Motor strain** – The motor in an electric recliner is designed to operate under conditions where the load is evenly distributed. When the floor is not level, the motor works harder to adjust the recliner, leading to increased wear and tear over time.
- 2.Uneven Movement** – An electric recliner on an uneven floor may not operate smoothly or evenly. This can result in jerky movements, uneven reclining, or difficulty in adjusting the position, potentially causing discomfort for the user.

Moving your recliner

- Always ensure that the recliner is upright when transporting.
- Moving or transporting reclining sofas can be challenging due to their weight, which includes the mechanism and frame. Always ensure there are at least two people to lift the weight properly and avoid dragging or dropping the recliner as it can cause bending and bowing of the mechanism.
- Do not pull your sofa by the cushions and fabric as this will result in tears and rips.

CARE AND MAINTENANCE

REGULAR CARE:

- Protect from direct sunlight
- Vacuum regularly using low suction
- Rotate reversible cushions regularly
- Avoid exposure to new clothing, cushions or throws as this may lead to dye transfer and permanent staining

CLEANING:

- Do not remove cushion covers for separate cleaning even though they may have zippers
- Do not wash, Do not dry clean, Do not shampoo clean
- Clean only with hot water extraction machine. Professional cleaning recommended
- Do not use dishwashing liquid or laundry detergent. Use only upholstery detergents
- Do not wet filling
- Dry in shade away from direct heat and sunlight
- Allow to dry thoroughly before re-use

SPOT CLEANING:

- Do not rub
- Do not spot clean with any solvent
- Treat spills and stains as soon as possible
- Gently scrape off any soil or blot any liquid from the surface of the fabric before applying cleaner
- Apply proprietary cleaning agents strictly according to instructions to remove the residue of the spill
- Do not saturate the fabric or interior with water or other cleaning liquids

WARNING:

Apply only water-based soil resist (fabric protection) treatments. Do not use aerosol products

* PILLING IS NOT A FABRIC DEFECT OR FAULT AND IS NOT COVERED BY WARRANTY

* PILLING IS A NORMAL OCCURRENCE IN WOVEN FABRICS AND DOES NOT AFFECT THE DURABILITY OR FUNCTIONALITY OF THE FABRIC. IT IS EASILY REMOVED BY USE OF A BATTERY OPERATED DE-PILLING MACHINE AS THE NEED ARISES